

OFFLINE Coolers

Air Cooled Range / CC-Rail / 20/30 lpm



General Data and Details

The oil / air coolers of our CC series are autonomous cooling systems with an integrated circulation pump. They work as a separate cooling unit or as a filter cooling unit with an adequate filter. The benefits of such circulation coolers are a constant cooling performance and a higher durability, because there are no pressure vibrations or peaks in the cooler unit.

Conditions of use:

Maximum oil temperature: 80°C, maximum air temperature: 50°C. Motors can be used up to an altitude of 1.500m. For other conditions of use please contact our engineers.

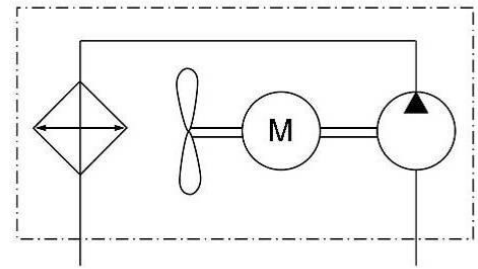

Connection asa rail

The **asa** rail system is the first worldwide flexible mounting and connection system for air blast heat exchangers. It gives you the free choice of the connector direction through turnable ports. The rail slots in the radiator are the frame structure not only for connecting the ports, also for various possible mounting arrangements such as bypass systems, mounting of the cooler to aggregates, measurement devices and much more. Please contact us to discover the huge potential of this system for your application.

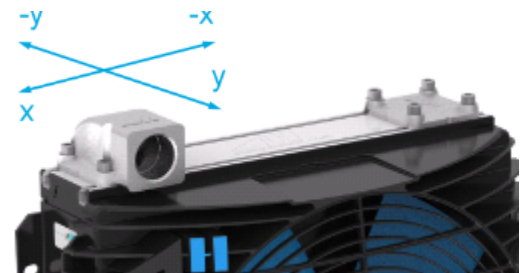

Scale Drawing

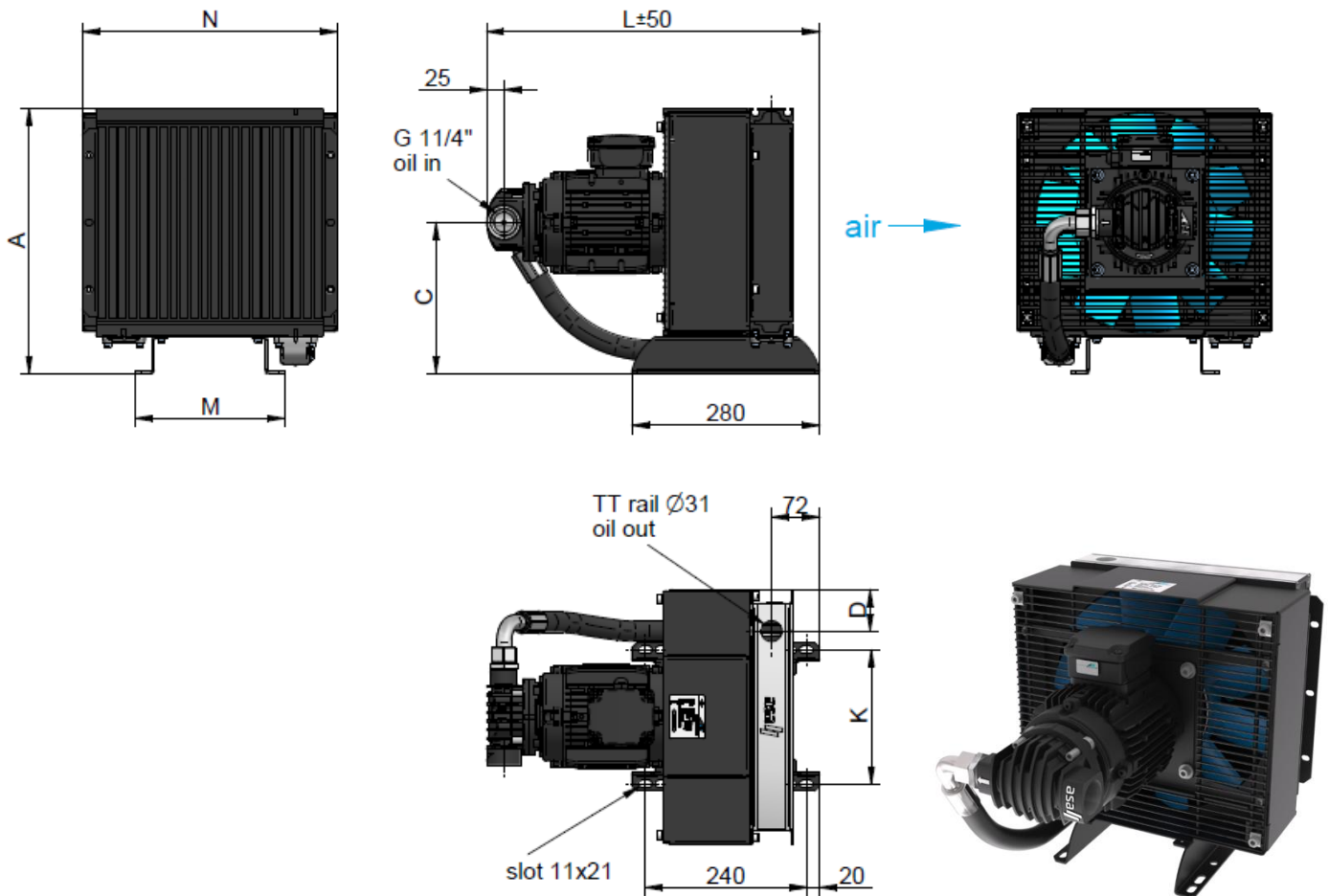

This data sheet and the corresponding scale drawings are to be used as a general guideline and technical overview of our products. Please contact us if more exact information is needed. As we are constantly improving our products, their characteristics, dimensions and weights may also change, although we do our best to incorporate these changes continually. asa assumes no liability for any information therein, any errors, omissions, misprints, nor any direct or indirect damages, losses or costs resulting therefrom. Any cooling performances and general technical values indicated in this catalogue are measured at a test bench according to asa testing procedures or calculated, based on such tests. Due to different conditions in testing and application environments the performance may also vary by +/- 15%. Because there is no standardized testing procedure, tests used by other manufacturers could have different results. Therefore we recommend all products to be checked under the system operating conditions. This is also true for vibrations and mechanical stress as well as for pressure peaks and thermal stress and any other relevant factors. General tolerances according to DIN ISO 2768-vL, General tolerances for casted parts according to EN ISO 8062-3 (DCTG 10). Tolerances for rubber parts are according to ISO 3302-1 (class M4-F+C). The tolerances of welding seams are defined by quality group D according to EN ISO 10042, if it is not specified on the actual scale drawing or data sheet. In addition to that we point out that any data sheet and corresponding scale drawing is no substitution for the manual.

DD-CC-Rail-en-rev0 © asa technology, May 2021 page 1/2

Performance

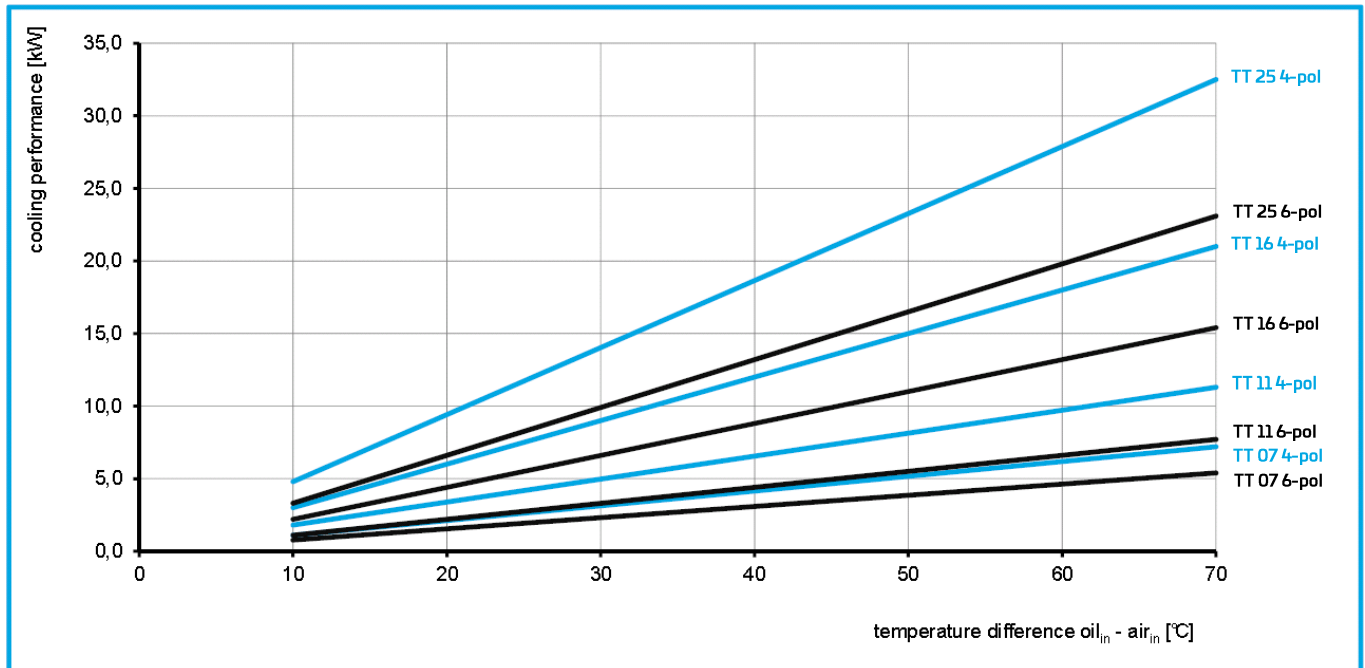

Technical Data

order number	description	oil flow	max. working pressure	motor power	motor current	rotation	air flow	noise level	weight	A	C	D	K	L	M	N
		[lpm]	[bar]	[kW]	[A]	[rpm]	[kg/s]	[dB(A)]	[kg]	[mm]	[mm]	[mm]	[mm]	[mm]	[mm]	[mm]
ASATT07RA47CC	TT 07 rail CC 4-pol	30	10	0,75	1,7	1445	0,19	65	24,4	355	205	72	135	493	157	320
ASATT11RA47CC	TT 11 rail CC 4-pol	30	10	0,75	1,7	1445	0,48	68	28,3	395	225	62	200	495	222	380
ASATT16RA47CC	TT 16 rail CC 4-pol	30	9	0,75	1,7	1445	0,64	74	35,8	520	288	66	200	511	222	460
ASATT25RA47CC	TT 25 rail CC 4-pol	30	6	0,75	1,7	1445	2,00	79	44,4	660	358	68	300	511	322	558
ASATT07RA66CC	TT 07 rail CC 6-pol	20	9	0,37	1,17	935	0,13	57	24,5	355	205	72	135	493	157	320
ASATT11RA66CC	TT 11 rail CC 6-pol	20	8	0,37	1,17	935	0,32	58	28,4	395	225	62	200	495	222	380
ASATT16RA66CC	TT 16 rail CC 6-pol	20	8	0,37	1,17	935	0,44	65	35,9	520	288	66	200	511	222	460
ASATT25RA66CC	TT 25 rail CC 6-pol	20	6	0,37	1,17	935	1,30	68	44,5	660	358	68	300	511	322	558

The maximum suction pressure is -0,4 bar. The viscosity range is <100cSt. Motor voltage: 230/400V @ 50Hz*. The protection level is IP55.

Design

radiator material	aluminium
radiator air fin shape	wavy
pump type	gerotor
pump material (housing)	aluminium
sheet metal material	powder coated steel
suitable fluids	mineral oil

Connection (BSP 1")

ILLZATT53G25K	requires 1pc per cooler
---------------	-------------------------

Options

asa rail connector	BSP 1 ¼"
temperature switch	50°C, 60°C
Rail filter	integrated spin on filter (page 15)
motor data*	alternative voltages, frequencies, protection levels, etc on request

