



H-Cube System

hydraulic oil conditioning
cooler • filter • oil tank • fan drive



discover the
customized
standard.

H-Cube Series

modular cooler, filter, tank and control link



Main features and benefits of the H-Cube system

The H-cube is a modular system, which offers three tank sizes with four oil/air cooler sizes, various fan drive types and a suction or return line filter. With its compact dimensions and the flexibility of cooling performances and oil tank volumes, this system can easily be set up in various hydraulic applications. Choose the accessories from our big range to customize the product to your application!

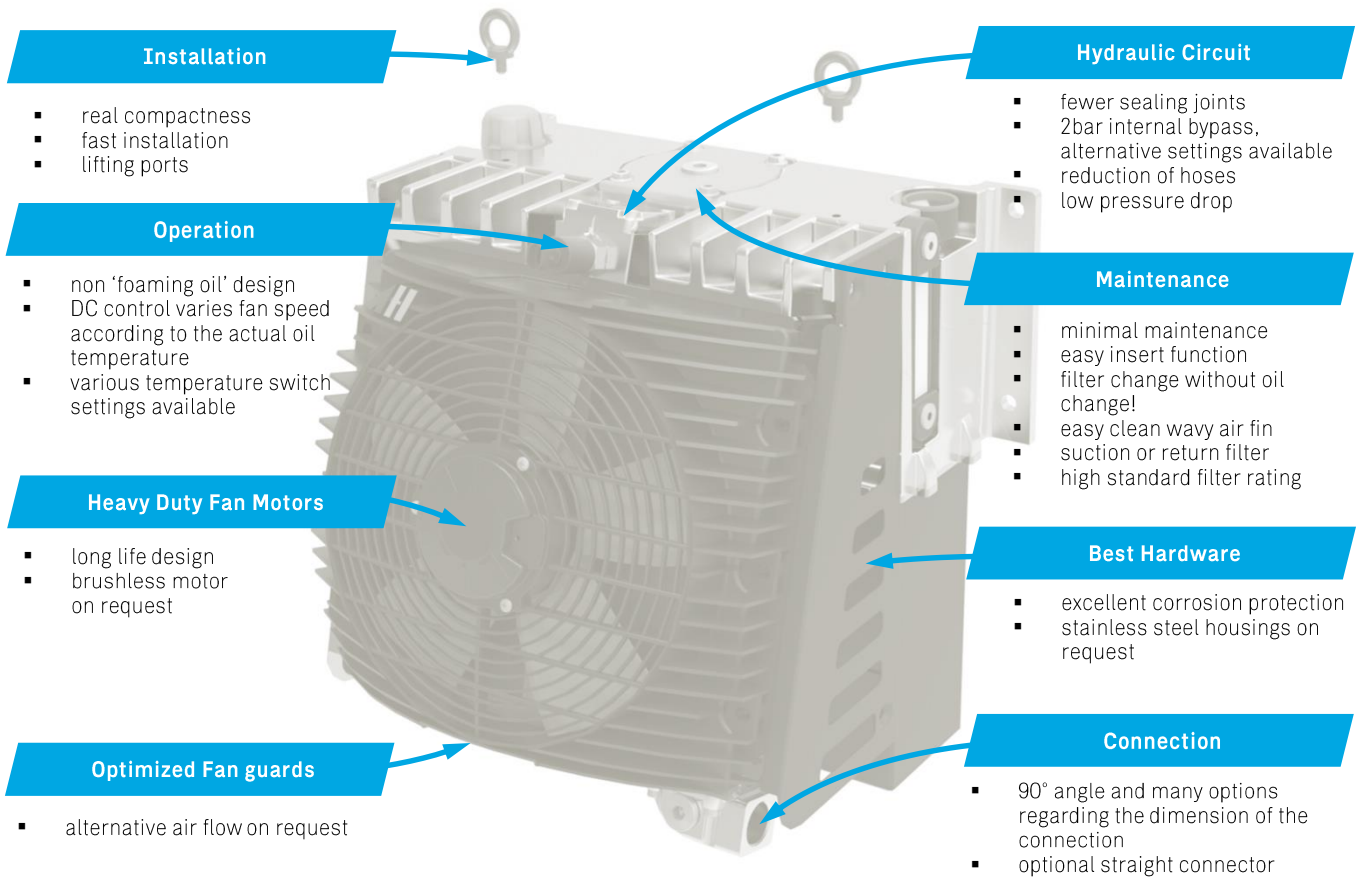

Applications

Due to the flexible design concept, the H-cube system can be configured to various applications. One main benefit is, that the H-cube system can be flanged directly onto the framework of a truck, as well as transverse to the driving direction.

- live floor trailers
- front axle drive service unit
- silos transporters
- liquid tankers like crude oil trucks
- food & chemical transporters
- compressor drive systems
- ...



direct mounting or transverse to truck frame!

This data sheet and the corresponding scale drawings are to be used as a general guideline and technical overview of our products. Please contact us if more exact information is needed. As we are constantly improving our products, their characteristics, dimensions and weights may also change, although we do our best to incorporate these changes continually. asa assumes no liability for any information therein, any errors, omissions, misprints, nor any direct or indirect damages, losses or costs resulting therefrom. Any cooling performances and general technical values indicated in this catalogue are measured at a test bench according to asa testing procedures or calculated, based on such tests. They represent a basis for your product selection. Due to different conditions in testing and application environments the performance may also vary by +/- 15%. All sound values are determined in accordance with ISO 9614-2, DIN EN ISO 11203 accuracy class 3 or Machinery Directive 2006/42/EG and are A-rated. At some of the performance data, possible differences to competition data are possible. The reason to that are no existing standardized testing procedures on individual subjects, e.g. for cooling performance measurements. Therefore, we recommend all products to be checked under the system operating conditions. This is also true of vibrations and mechanical stress as well as for pressure peaks and thermal stress and any other relevant factors. General tolerances according to DIN ISO 2768-vL, General tolerances for casted parts according EN ISO 8062-3 (DCTG 10). Tolerances for rubber parts are according to ISO 3302-1 (class M4-F+C). The tolerances of welding seams are defined by quality group D according to EN ISO 10042, if it is not specified on the actual scale drawing or data sheet. Any form of liability is excluded for the information included in this datasheet. All details and calculation values are checked to the best of our ability, but these do not ensure any intrinsic product properties: due to the wide-ranging possible applications, it is advised that all technical data herewith included be confirmed through testing carried out by the end-user. asa technology Produktions- und Vertriebs GmbH reserves the right to modify the product without any separate notification. This refers to both technical data and the product itself. Furthermore, it is herewith specified that the datasheet does not substitute the corresponding scale drawings, assembly and installation guidelines, nor the operating instructions.

DD-H-Cube-en-rev14 © asa technology, January 2023 2/8

H-Cube Series

modular cooler, filter, tank and control link



Design your own H-cube!

The integration block connects tank, filter and heat exchanger. These components can be, individually, varied in size and function. As a result the system can be customized to the application, while remaining a standard range product. Also integrated are tank level gauge, bypass valve, clogging indicator and temperature switch port. Due to this flexible system, all parts can be combined with the same control flange. The table below shows the possible options and its resulting code.

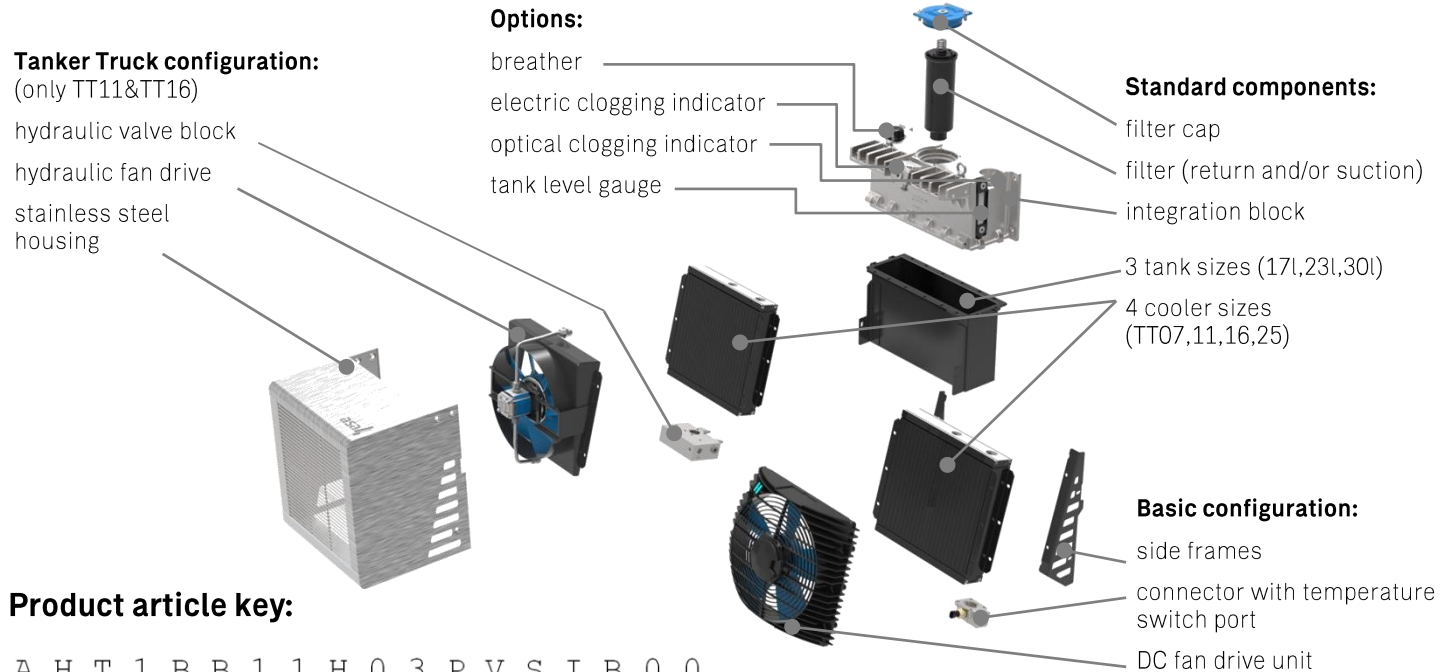

Product article key:

A H T 1 B B 1 1 H 0 3 P V S I B 0 0

1 2 3 4 5 6 7 8

1 Product Series

AH	ASA H-Cube
----	------------

2 Tank Size*

T1	tank with 17l (EU**)
T2	tank with 23l (EU**)
T3	tank with 30l (EU**)
R5	tank with 4.5gal (US**)
R6	tank with 6.1gal (US**)
R8	tank with 7.9gal (US**)

3 Filter Combinations

	return filter	suction filter
00	none	none
B0	6µm (max.88lpm)	none
C0	10µm (max.180lpm)	none
D0	16µm (max.185lpm)	none
E0	25µm (max.195lpm)	none
0B	none	90µm
BB	6µm (max.88lpm)	90µm
CB	10µm (max.180lpm)	90µm
DB	16µm (max.185lpm)	90µm
EB	25µm (max.195lpm)	90µm

4 Cooler Size/Type

07	TT 07 rail, 2bar(30psi) bypass
11	TT 11 rail, 2bar(30psi) bypass
16	TT 16 rail, 2bar(30psi) bypass
25	TT 25 rail, 2bar(30psi) bypass

5 Fan Drive

D01	12V DC
D02	24V DC
H03	3cm ³ hydraulic

7 Clogging Indicator

0	no indicator
I	optical clogging indicator
E	electric clogging indicator

8 Index / Customized

Bxx	special / customized specifications, to be advised e.g. position of connectors, special connectors, etc...
-----	--

6 Accessories & Options***

000	no options
00S	only stainless steel housing
KTO	temperature control DC
KTS	temp. control & stainless steel housing
PVS	tanker truck ¹⁾ block 210bar (3040 PSI) & stainless steel housing
PHS	tanker truck ¹⁾ block 350 bar (5070 PSI) & stainless steel housing

* complete system content,

** EU version truck frame flange 150 x 450mm and BSP suction port
US version truck frame flange 5.5 x 17.5inch and NPT suction port

*** stainless steel and protection housing not in combination with cooler size TT 25!

¹⁾ Only in combination with cooler sizes 11 & 16. Tanker Truck configurations include the functions of a adjustable pressure relief valve for the whole hydraulic system, return line connection and hydraulic fan drive control -> see more information on the H-Cube data sheet, page 5 or contact us for further assistance.

H-Cube Series

modular cooler, filter, tank and control link



Dimensions

There are 4 different cooler sizes which can be combined with 3 different tank sizes. According to each individual combination, the dimensional drawing is different. Please see below main measurements that are invariant on that system.

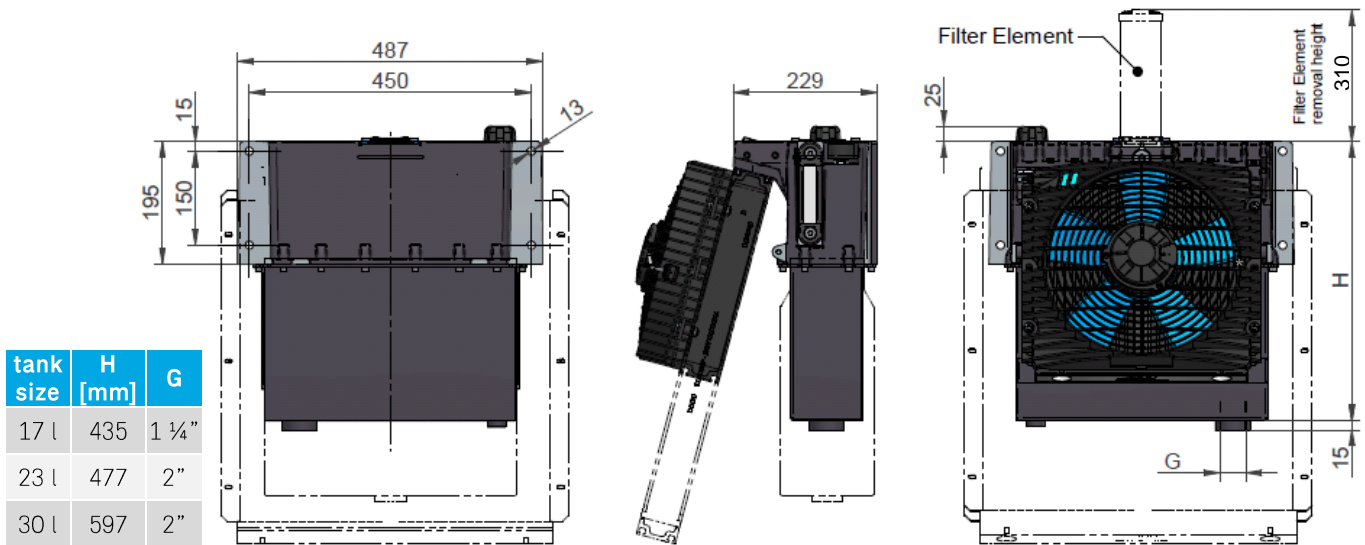

Performance Selection

The actual performance output of the H-cube system is a combination of the cooler size (radiator core) and the type of fan drive. Choose the possible performances from the table below. The shown performance is the maximum possible specific cooling performance depending on the oil flow (chart on the left side). For the tanker truck versions you can also select the cooler size as a function of pressure and oil flow (chart on the right side).

specific cooling performance (with 12V or 24V DC fan drive)

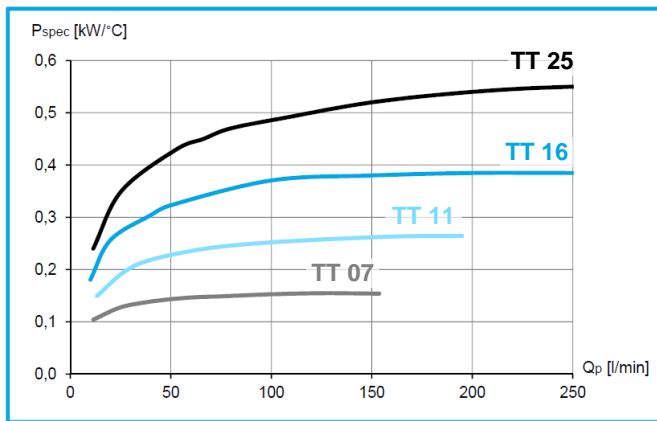

cooling performance range (tanker truck types), to select by pressure and oil flow

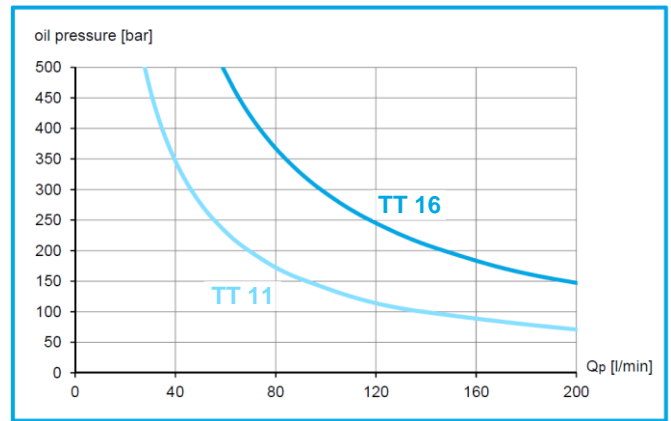

Specifications

The materials in our standard configuration are designed for mobile applications, but can also be used for industrial applications. Our high corrosion protection standard provides life time excellence to any configured package.

radiator material	brazed aluminium
radiator air fin	wavy
tank material	steel
integration block	cast aluminium

return filter rating	6 µ to 25 µ with 1,75 bar bypass
suction filter rating	90 µ (other micron on request)
fan drive	12V / 24V DC or hydraulic
weight (dry)	27 kg to max. 53 kg

This data sheet and the corresponding scale drawings are to be used as a general guideline and technical overview of our products. Please contact us if more exact information is needed. As we are constantly improving our products, their characteristics, dimensions and weights may also change, although we do our best to incorporate these changes continually. asa assumes no liability for any information therein, any errors, omissions, misprints, nor any direct or indirect damages, losses or costs resulting therefrom. Any cooling performances and general technical values indicated in this catalogue are measured at a test bench according to asa testing procedures or calculated, based on such tests. They represent a basis for your product selection. Due to different conditions in testing and application environments the performance may also vary by +/- 15%. All sound values are determined in accordance with ISO 9614-2, DIN EN ISO 11203 accuracy class 3 or Machinery Directive 2006/42/EG and are A-rated. At some of the performance data, possible differences to competition data are possible. The reason to that are no existing standardized testing procedures on individual subjects, e.g. for cooling performance measurements. Therefore, we recommend all products to be checked under the system operating conditions. This is also true of vibrations and mechanical stress as well as for pressure peaks and thermal stress and any other relevant factors. General tolerances according to DIN ISO 2768-vL. General tolerances for casted parts according to EN ISO 8062-3 (DCTG 10). Tolerances for rubber parts are according to ISO 3302-1 (class M4-F+C). The tolerances of welding seams are defined by quality group D according to EN ISO 10042, if it is not specified on the actual scale drawing or data sheet. Any form of liability is excluded for the information included in this datasheet. All details and calculation values are checked to the best of our ability, but these do not ensure any intrinsic product properties: due to the wide-ranging possible applications, it is advised that all technical data herewith included be confirmed through testing carried out by the end-user. asa technology Produktions- und Vertriebs GmbH reserves the right to modify the product without any separate notification. This refers to both technical data and the product itself. Furthermore, it is herewith specified that the datasheet does not substitute the corresponding scale drawings, assembly and installation guidelines, nor the operating instructions.

DD-H-Cube-en-rev14 © asa technology, January 2023 4/8

H-Cube Series

modular cooler, filter, tank and control link



H-Cube configuration example: Tanker Truck

The H-Cube system can also be configured with a control block for relief valve function and flow control. This system is mainly used on tanker trucks and is a very compact cooling and filtration solution for your hydraulic system.

Setup Example H-Cube T1-OB-16-H03-PVS-I-B00

This compact and real light weight system is an efficient hydraulic control and conditioning module for continuous operation. This system allows heavy duty operation while controlling oil filtration and temperature.

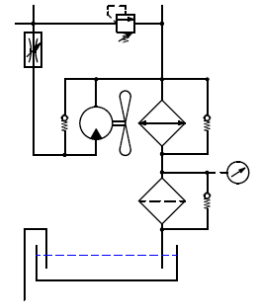

- *stainless steel housing*
- *17 l oil tank*
- *hydraulic fan drive*
- *relief valve*
- *flow control*
- *35 bar to 210 bar*
- *up to 250 lpm*
- *corrosion and vibration resistant*
- *many customizing options...*

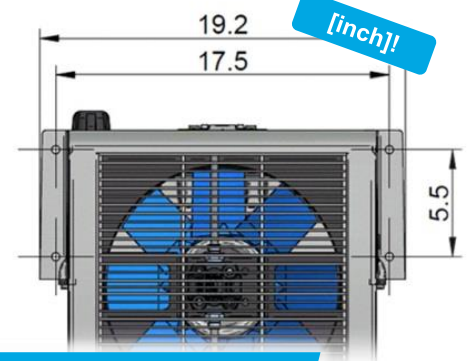
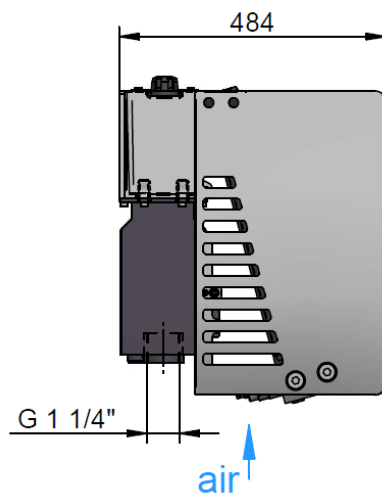
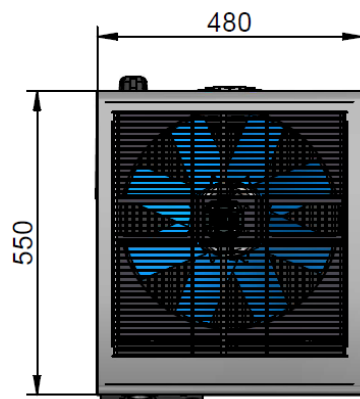
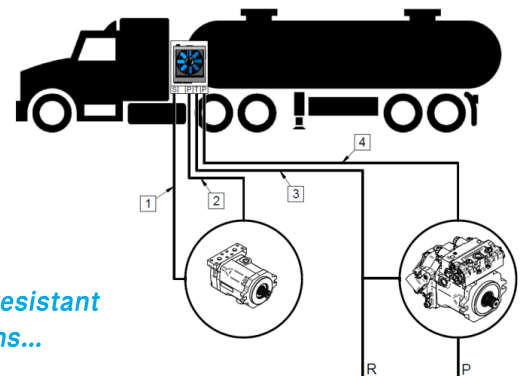

**US frame on request!
(17.5in x 5.5in)**

Cross Reference List for Tanker Truck Configurations

asa reference number	competitor product
H-Cube T1-C0-11-H03-PVS-I-B00	GD HK3 Hydrapak
H-Cube R5-C0-16-H03-PVS-I-B00	GD MH5 Hydrapak
H-Cube R5-C0-11-H03-PVS-I-B00	GD MH3 Hydrapak
H-Cube R5-C0-16-H03-PHS-I-B00	PSG (Blackmer) Hydrive 2020
...contact us for further comparisons!	

This data sheet and the corresponding scale drawings are to be used as a general guideline and technical overview of our products. Please contact us if more exact information is needed. As we are constantly improving our products, their characteristics, dimensions and weights may also change, although we do our best to incorporate these changes continually. asa assumes no liability for any information therein, any errors, omissions, misprints, nor any direct or indirect damages, losses or costs resulting therefrom. Any cooling performances and general technical values indicated in this catalogue are measured at a test bench according to asa testing procedures or calculated, based on such tests. They represent a basis for your product selection. Due to different conditions in testing and application environments the performance may also vary by +/- 15%. All sound values are determined in accordance with ISO 9614-2, DIN EN ISO 11203 accuracy class 3 or Machinery Directive 2006/42/EG and are A-rated. At some of the performance data, possible differences to competition data are possible. The reason to that are no existing standardized testing procedures on individual subjects, e.g. for cooling performance measurements. Therefore, we recommend all products to be checked under the system operating conditions. This is also true of vibrations and mechanical stress as well as for pressure peaks and thermal stress and any other relevant factors. General tolerances according to DIN ISO 2768-vL, General tolerances for casted parts according to EN ISO 8062-3 (DCTG 10). Tolerances for rubber parts are according to ISO 3302-1 (class M4-F+C). The tolerances of welding seams are defined by quality group D according to EN ISO 10042, if it is not specified on the actual scale drawing or data sheet. Any form of liability is excluded for the information included in this datasheet. All details and calculation values are checked to the best of our ability, but these do not ensure any intrinsic product properties: due to the wide-ranging possible applications, it is advised that all technical data herewith included be confirmed through testing carried out by the end-user. asa technology Produktions- und Vertriebs GmbH reserves the right to modify the product without any separate notification. This refers to both technical data and the product itself. Furthermore, it is herewith specified that the datasheet does not substitute the corresponding scale drawings, assembly and installation guidelines, nor the operating instructions.

DD-H-Cube-en-rev14 © asa technology, January 2023 5/8

H-Cube Series

modular cooler, filter, tank and control link



H-Cube configuration example: Auxiliary Truck Drive

The H-Cube system can be configured to various applications. Auxiliary truck drives are circuits to assist the drive train at low speed on gravel or other rough road conditions. Such temporary hydraulic drive circuits require a high cooling performance over a short operation period.

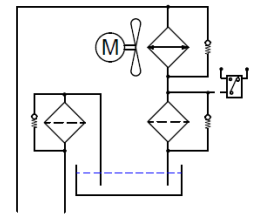

Setup Example H-Cube T1-CB-16-D02-E-B00

In this example the 17 l oil reservoir, TT 16 size cooler and filters (return and suction) have been selected. The compactness and cost savings against a conventional system with separate components proves the comprehensive efficiency of this system.

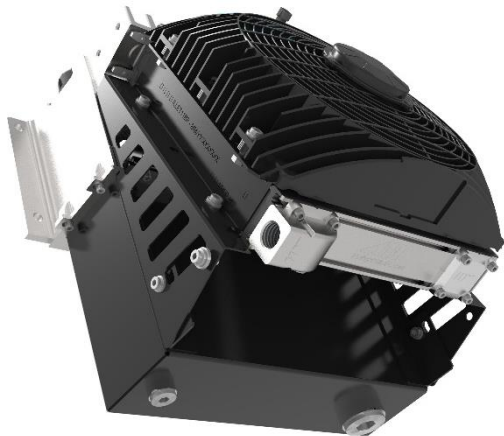

- 24V DC fan drive
- IP 68 motor protection
- 17l oil reservoir
- return filter 10µm
- suction filter 90µm
- up to 250 lpm
- corrosion and vibration resistant
- temperature control options
- clogging indicator switch

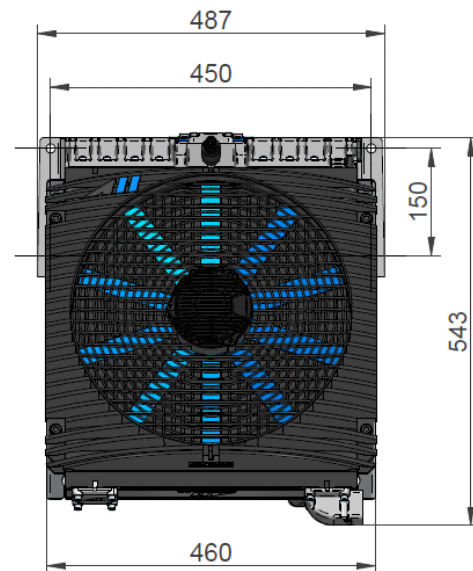
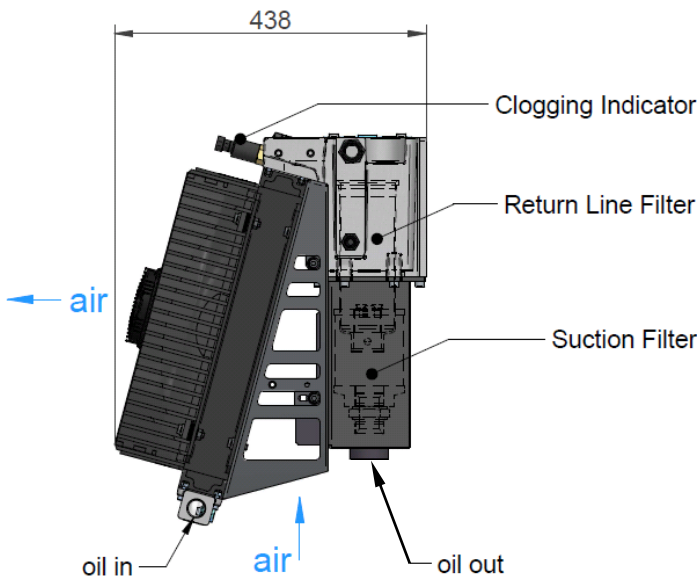
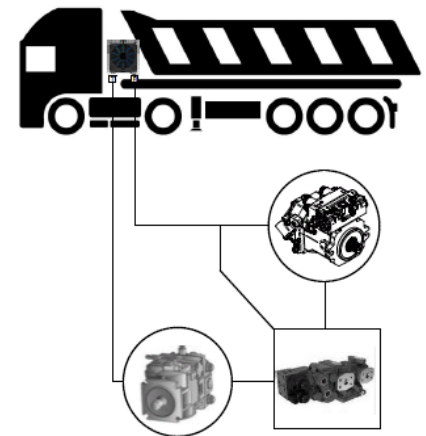

H-Cube Series

modular cooler, filter, tank and control link



Reliability in all fields

Best Warranty



We offer you a very strong warranty period of one-year. This period begins on the actual start up date of the equipment, provided that date is within six month of receipt of goods. Our high quality is proven by successful ISO 9001 certification on our asa production facilities, as well as ISO 14001 and OHSAS 18001 certification.

Best Service



Send us your enquiries or call our head offices or distribution partners. Our goal is to support any of your requirements and wishes of technically and economic belongings. Our online calculation program has free access and is very easy to use.

Best Packing

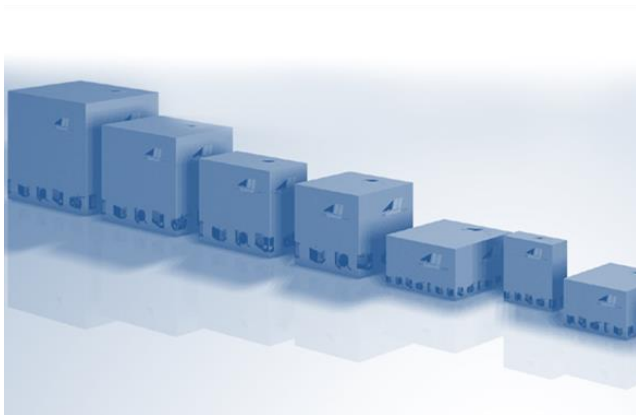

Single orders, delivery batches, containers: we help you to figure out the most economic way to transport the goods. Let us try to keep your expenses to what they are supposed for and not to the forwarding agents and useless packaging material.

Best Availability



We build your order in record time! Our unique lead time of 5 – 10 working days ex works on standard products provide the highest flexibility to your time schedule.

**be different.
make a difference.**

AUSTRIA

asa technology Produktions-
und Vertriebs GmbH
Prager Strasse 280
A-1210, Vienna
Tel.: +43 1 292 40 20
support@asahydraulik.com

AUSTRALIA

asa Products Pty Ltd
Quinlan Road 23
3076 Epping, Victoria
Tel.: +61 3 9397 6129
melbourne@asahydraulik.com

Brasil

asa hydraulik to Brasil Ltda
Rua Maria Fett 96
03263-000 Vit Mercedes, Sao Paulo
Tel.: +55 11 9 8862-0022
salesbrazil@asahydraulik.com

CHINA

asa Hydraulik Technology (Suzhou) Co.Ltd
江苏省苏州市工业园区方洲路 128 号 6 区 B 幢
Area 6, Building B,
Fangzhou Road No 128,
Suzhou industrial park,
Suzhou City, Jiangsu Province
Tel.: +86 512 62381988
suzhou@asahydraulik.com

INDIA

asa heatexchanger Pvt Ltd
Plot no.1226, Phase-3, GIDC, Vatva
Ahmedabad - 382445
Tel.: +91 70 43907273
salesindia@asahydraulik.com

USA

asa hydraulik of America
160 Meister Avenue 20 A
Branchburg, New Jersey 08876
Tel.: +1 800 473 94 00
Tel.: +1 908 541 15 00
sales_us@asahydraulik.com

